

# FIXMAN®



## Vermont Sales

SOUTH AFRICA'S #1 SUPPLIER (Pty) Ltd  
of power tool accessories

4th Edition

# The Brand



FIXMAN is the leading brand in the hand tools field. Involved over twenty years in the automotive industrial and construction field



## FIXMAN Technology and Equipment

With almost 20 years' experience of manufacturing, by bring in modern equipment, advanced technology and standardized management, we are able to bring out a high quality product through out the process including raw material ,forging, mechanism, hardening and finishing.



## FIXMAN Research and Development

We know innovation is the drive of company's development, in order to constantly get it, we set up a special team, who is committed to research, audit, design, testing and standard-setting. Beside that, we also cooperate with colleges and universities, to absorb new theory and new idea from them.



## FIXMAN Quality and Control

Apply to international standard, by modern testing equipment,our QC people control the quality strictly, to ensure the customer that every product they get ,would meet their satisfaction.



## FIXMAN Logistics and Service

Our mature logistics and service system, enable every step of operation is tracked by computer and special service team, through out the order placing, stock checking, purchasing, producing, packing, testing, shipping and after service. To ensure the customer a full controllability and reliability assurance.



Roller Cabinets and Storages

**P02**

Tool Sets

**P10**

Sockets and Accessories

**P20**

Wrenches

**P32**

Pliers

**P39**

Hammers

**P46**

Hacksaws

**P48****INDEX**



## Safety First !

The goal of FIXMAN is to produce tools that help you work safely and efficiently. The most important safety environment is depending on you, consideration are the best protection against injury, all possible hazards cannot be covered here, but we have tried to highlight some of the important ones.



Never open more than one drawer at the same time, in order to avoid the unit topple down.



No prying.



Do not stand in the drawers.



Do not over torque.  
No pipes or lever.



Always push the cabinet before you instead of pulling it, and keep all the items on the top balanced.



Do not strike hard objects.



Can not be slanted over 5°.



Do not place feet under any moving part of lift while lowering.



Do not exceed the drawers loading capacity.



Mandatory mask.



Apply the brake when stationary, be sure all drawers are closed before moving.



Mandatory ear protection.



Mind your hands and wear gloves. Sharp or rough objects should not be kept loose.



Mandatory face shield.



Handle with great care when loading and unloading.



Mandatory respirator.



Must read instructions before use.



Risk of explosion.

# Workshop Storage

Roller Cabinet, Chests, Tool Box...



## F1 Series Professional



- Full double wall construction feature two full layers of heavy duty steel provide strength and durability.
- Side perforated panels provide an extension tools and accessories placed.



Central locking system provides security.



High intensity worktop with integrated ergonomic handle.



Full extension ball bearing drawer slides offer a smooth open and close, and an increased loading ability.



Anti-shock protection on all four corners.



Drawer release mechanism incorporated within the handle, to prevent accidental drawer opening.



Heavy duty wheels.  
-125mm diameter for easy crossing of obstacles.  
-Two fixed wheels and two castors, one with brake.

### FIXF1RP7 7-Drawers Roller Cabinet

• **Drawer:**

- 4 x Small drawers : 533 x 391 x 58mm : Load 25Kg
- 3xMedium drawers : 533 x 391 x 128mm : Load : 35Kg

• **Wheel:**

- φ125mm
- 2 x Fixed, 2 x Castors (1 with brake)

• **Cabinet weight:**

57Kg;

• **Cabinet size:**

958 x 766 x 465mm

- Uses Fixman's Modular storage system
- Modules sold separately



EMPTY



## FIX C1RP4-1 4-Drawers Roller Chest

- **Drawer:**  
4 x Small drawers : 533 x 391 x 58mm : Load 25Kg
- **Wheel:**  
Φ125mm  
2 x Fixed, 2 x Castors (1 with brake)
- **Cabinet weight:**  
43Kg
- **Cabinet size:**  
690 x 465 x 545mm
- Pull Handle folds down to save space when not in use
- Modules sold separately



**EMPTY**



## FIX M1RP7B 7-Drawers Roller Chest

- **Cabinet size:**  
766x465x958mm;
- **Drawer:**  
4 x Small drawers:533 x 391 x 58mm : Load 25kg  
1 x Medium draw : 533 x 391 x 128mm : Load 25kg  
1 x Large drawer size : 533 x 391 x 195mm : Load 25kg
- **Wheel:**  
Φ100mm  
2 x Fixed, 2 x Castors (1 with brake)
- **Cabinet Weight:**  
43kg
- Comes with 9 modules



**WITH STOCK**



## COMES WITH 9 MODULES



F1BT35



F1BT06-1



F1BT37



F1BT24



F1BT07



F1BT83



F1BT13



F1BT23



F1BT28

# Tool Modular Storage System



## **FIXMAN Modular Storage System**

Comprising of over 40 modules, the FIXMAN modular storage system allows each tool to be easily selected and missing tools to be immediately recognized. It is fully compatible with the roller cabinets and work bench

The Trays forming the modules are designed to withstand intensive daily use. Full details of the range are given in the following pages, as well as the various tool sections



## Blow Mould Case Tool Trays

### FIX F1BT35

19-pc 1/4" Dr. Sockets & Accessories



### FIX F1BT70

56-pc 1/4"Dr. Sockets & Accessories

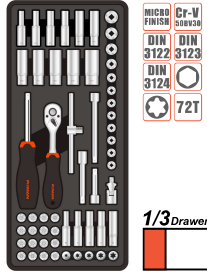

### FIX F1BT49

33-pc 1/4"Dr. Sockets & Accessories

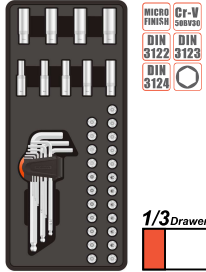

### FIX F1BT64

57-pc 1/4"Dr. Sockets & Accessories

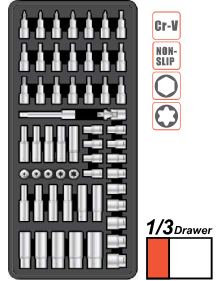

### FIX F1BT36

22-pc 3/8"Dr. Sockets & Accessories

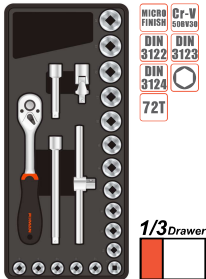

### FIX F1BT48

31-pc 3/8" Dr. Sockets & Accessories

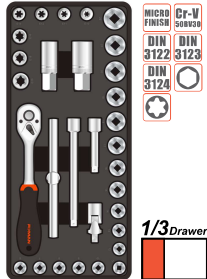

### FIX F1BT73

20-pc 3/8"Dr. Sockets & Accessories

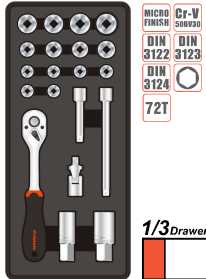

### FIX F1BT72

24-pc 3/8"Dr. Sockets & Accessories

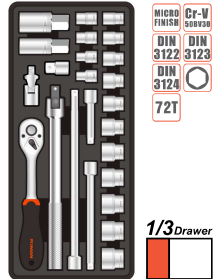

### FIX F1BT71

26-pc 3/8"Dr. Sockets & Accessories



### FIX F1BT79

34-pc 3/8"Dr. Sockets



### FIX F1BT76

19-pc 1/2"Dr. Sockets & Accessories



### FIX F1BT37

22-pc 1/2" Dr. Sockets & Accessories

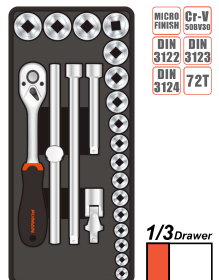

## FIX F1BT23

3-pc Adjustable Wrench  
6"-8"-10"



Cr-V  
NON-SLIP

1/3 Drawer



## FIX F1BT47

26-pc 1/2" Dr. Sockets  
& Accessories



MICRO FINISH Cr-V SOXV30  
DIN 3122 DIN 3123  
DIN 3124 72T

1/3 Drawer



## FIX F1BT74

6-pc 1/2"Dr. Accessories



MICRO FINISH Cr-V SOXV30  
DIN 3122 DIN 3123  
72T

1/3 Drawer



## FIX F1BT75

5-pc 1/2"Dr. Accessories



MICRO FINISH Cr-V SOXV30  
DIN 3122 DIN 3123  
72T

1/3 Drawer



## FIX F1BT60

21-pc 1/2"Dr. Sockets

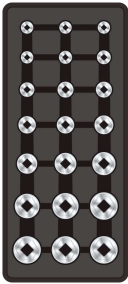

MICRO FINISH Cr-V SOXV30  
DIN 3124

1/3 Drawer



## FIX F1BT61

27-pc 1/2"Dr. Sockets

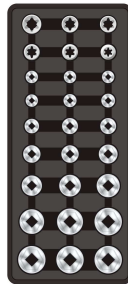

MICRO FINISH Cr-V SOXV30  
DIN 3124

1/3 Drawer



## FIX F1BT62

16-pc 1/2"Dr. Deep Sockets



MICRO FINISH Cr-V SOXV30  
DIN 3124

1/3 Drawer



## FIX F1BT63

12-pc 1/2"Dr. Deep Sockets



MICRO FINISH Cr-V SOXV30  
DIN 3124

1/3 Drawer



## FIX F1BT06-1

17-pc Combination  
Spanners 6 to 22mm

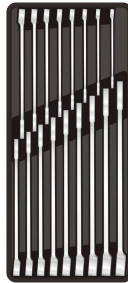

Cr-V  
DIN 3113

1/3 Drawer



## FIX F1BT30

6-pc Flare Nut Wrenches  
6 to 24mm



Cr-V  
DIN 3118

1/3 Drawer



## FIX F1BT55

5-pc Combination Spanners  
24 to 32mm



Cr-V  
DIN 3113

2/3 Drawer



## FIX F1BT24

8-pc Slotted & Philips Screwdrivers

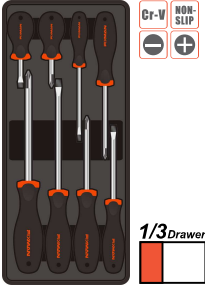

## FIX F1BT25

7-pc Slotted Screwdrivers

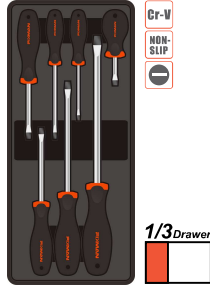

## FIX F1BT26

7-pc Philips Screwdrivers

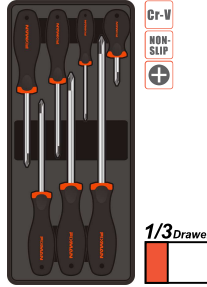

## FIX F1BT27

7-pc Torx Screwdrivers

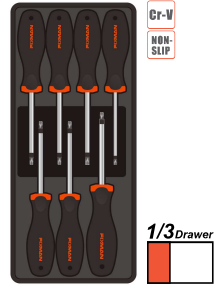

## FIX F1BT07

3-pc Pliers Set  
-Combination Pliers 8",  
-Long Nose Pliers 8",  
-Diagonal Cutting Pliers 7.5"

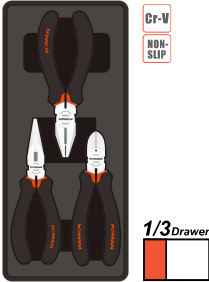

## FIX F1BT08

2-pc Pliers Set  
-Groove Joint Pliers 10",  
-Lock-grip Pliers 7"



## FIX F1BT28

4-pc 6" Internal & External  
Circclip Pliers

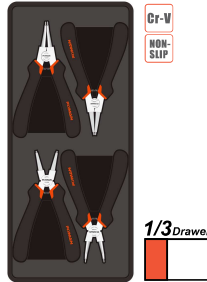

## FIX F1BT80

4-pc Pliers Set  
-Combination Pliers 7",  
-Diagonal Cutting Pliers 6",  
-Long Nose Pliers 8",  
-Bent Nose Pliers 8"

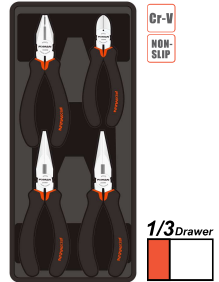

## FIX F1BT13

2-pc Machinist  
Hammer & Mallet



## FIX F1BT38

10-pc Drift Punches &  
Pin Punches



## FIX F1BT12

5-pc L-Handle Hex Keys With  
Ball Head

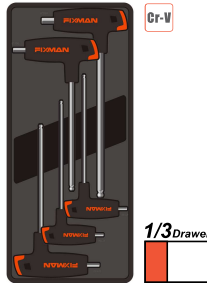

## FIX F1BT83

4-pc Hex & Torx Key Set





FIX F1BT23

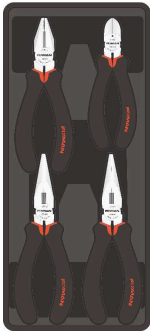

FIX F1BT80

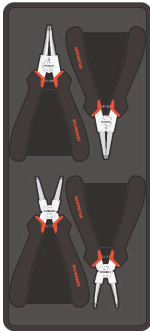

FIX F1BT28



FIX F1BT36



FIX F1BT37



FIX F1BT35

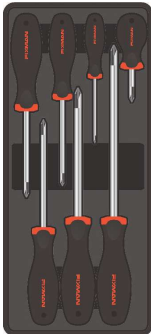

FIX F1BT26

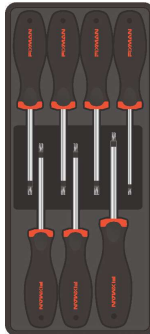

FIX F1BT27



FIX F1BT25



FIX F1BT13



FIX F1BT62



FIX F1BT06-

## FIX F1RP7-1

**7 DRAWERS** + **130 PCS**  
**ROLLER CABINET** **HAND TOOL**

SPECIFICATIONS	
Small Draw Qty	4
Medium Draw Qty	3
Small Drawer Dimensions	553x391x58mm
Medium Drawer Dimensions	533x391x128mm
Weight kg	57Kg
Dimensions mm	958x766x465mm



# Tool Sets

Socket Tool Set, Mechanic Tool Set, Home Use Tool Set...



# 王者 TIGER



Reinforced and Soft Handle



Attractive LOGO plate

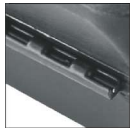

Steel Hinge



Metal Sense Harness



Anti-theft Protection



Unique Design



Metal Lock



Steady Stand





**72  
PIECES**

**Name 72-pc 1/4" & 1/2"Dr. Socket Tool Set**

**Item No. B5072M**

13 x 1/2"Dr. Socket	10-11-12-13-14-15-17-19-22-24-27-30-32mm
10 x 1/4"Dr.Socket	4-5-6-7-8-9-10-11-12-13mm
5 x 1/4"Dr. Deep Socket	5-6-7-8-9mm
2 x Universal Joint	1/2"Dr. & 1/4"Dr.
1 x 1/2"Dr. Extension Bar	125mm
1 x 1/4"Dr. Extension Bar	75mm
1 x 1/2"Dr. Spark Plug Socket	16mm & 21mm
1 x Spinner Handle	1/4"Dr.
1 x Coupler	1/4"Dr. X 1/4"
8 x Combination Wrench	10-11-12-13-14-15-17-19mm
1x Groove Joint Pliers	10"
1 x Combination Pliers	8"
1 x Machinist Hammer	300G
1 x Lock-Grip Pliers	10"
5 x Screwdriver	PZ2x100mm, 6.5x1.2x100mm, 6.5x1.2x38mm, PH2x100mm, PH2x38mm
14 x 1/4"Dr. 25mm(L) Bits	SL:3-4-5.5-6.5mm, PH:1-2-3, T:10-15-20-25-27-30-40
3 X Hex Key Wrench	1.5-2-2.5mm
2 x Ratchet Handle	1/2"Dr.&1/4"Dr.

QTY/CTN	CTN SIZE	G.W
3 sets	42.7x31.2x31cm	26.5kg





**65**  
PIECES

## 65-pc 1/2" & 1/4" Dr. Socket Tool Set

### Item No. FIX F1BT65

12x 1/4" Dr. Socket	4-4.5-5-5.5-6-7-8-9-10-11-12-13mm
14x 1/2" Dr. Socket	14-15-16-17-18-19-20-21-22-23-24-27-30-32mm
2x Ratchet Handle	1/4" & 1/2"Dr.
1x Spinner Handle	1/4"Dr.
2x 1/2"Dr. Spark Plug Socket	16mm&21mm
3x Extension Bar	1/2"Dr.x125 & 250mm, 1/4"Dr.x100mm
2x Universal Joint	1/4" & 1/2"Dr.
1x Three Way	1/2"Dr.
2x Coupler	1/2"x5/16", 1/4"x1/4"
4x Screwdriver	3x0.5x75mm, 5.5x1.0x100mm, PH0x75mm, PH1x100mm
12x 5/16"Dr. 30mm(L) Bit	H:4-5-6-7mm , T:20-25-27-30 , PH:1-2 , PZ:1-2
1x Long Nose Pliers	7"
1x Combination Plie	6"
8x Hex Key Wrench	1.5-2-2.5-3-4-5-5.5-6mm





**40**  
PIECES

Name **40-pc 1/2" Dr. Socket Tool Set**

Item No. **FIX OMCBT40**

1x Ratchet Handle	1/2"Dr.
1x 1/2"Dr. Spark Plug Socket	21mm
2x 1/2"Dr. Extension Bar	125&250mm
1x Universal Joint	1/2"Dr.
1x Three Way	1/2"Dr.
9x Combination Wrench	8-9-10-11-12-13-14-17-19mm
1x Machanist Hammer	300g
1x Long Nose Pliers	6"
1x Diagonal Cutting Pliers	6"
14x 1/2" Dr. Socket	14-15-16-17-18-19-20-21-22-23-24-27-30-32mm
8x 1/2" Dr. E Socket	E10-E12-E14-E16-E18-E20-E22-E24

QTY/CTN	CTN SIZE	G.W
3 sets	39.9x31.8x28.8cm	18.75kg





**84**  
PIECES

Name

**84-pc 1/4" & 1/2" Dr Socket Tool Set**

Item No. **FIX OMCBT84**

4 x Precision Screwdriver	PH:0-1,T:6-8	
1 x Long Nose Pliers	6"	
1 x Combination Pliers	7"	
1 x Magnetic Pick-up Tool	150mm	
24 x 25mm(L) Bit	SL:3-4-5-6-7mm,PH:0-1-2-3,T:10-15-20-25-27-30-40, H:2-3-4-5-6mm,S:1-2-3	
1 x Ratchet Screwdriver	1/4" Dr.	
13 x 1/4" Dr. Socket	4-4.5-5-5.5-6-7-8-9-10-11-12-13-14mm	
17 x 1/2" Dr. Socket	10-11-12-13-14-15-16-17-18-19-20-21-22-24-27- 30-32mm	
2 x Ratchet Handle	1/2" & 1/4" Dr.	
1 x Machinist Hammer	300g	
9 x Combination Wrench	8-10-11-12-13-15-16-17-19mm	
1 x Measuring Tape	3M/10FT	
8 x Hex Key Wrench	1.5-2-2.5-3-4-5-5.5-6mm	
1 x Torch	3W/LED, 93mm(L)	
QTY/CTN	CTN SIZE	G.W
3 sets	42.7x31.2x31cm	20.8kg



**42**  
PIECES



Name **42-pc 1/4" Dr. Socket Set**

Item No. **FIX B2042M**

13x 1/4" Dr. Socket	4-4.5-5-5.5-6-7-8-9-10-11-12-13-14mm
6x 1/4" Dr. Deep Socket	8-9-10-11-12-13mm
1x Universal Joint	1/4"Dr.
1x Sliding Bar	1/4"Dr.
1x Ratchet Handle	1/4"Dr.
1x Spinner Handle	1/4"Dr.
2x 1/4"Dr. Extension Bar	50mm&100mm
1x Coupler	1/4"Dr.
1x Flexible Extension Bar	1/4"Dr.
12x 1/4"Dr. 25mm(L) Bit	H: 4-5-6-7mm T:20-25-27-30 PH:1-2 PZ:1-2
3x Hex Key Wrench	1.5-2-2.5mm

QTY/CTN	CTN SIZE	G.W
6 sets	33.3x31.5x20.3cm	9.92kg



**20**  
PIECES



Name **20-pc 3/8" Dr. Socket Set**

Item No. **FIX B3020M**

15x 3/8" Dr. Socket	8-9-10-11-12-13-14-15-16-17-18-19-20-21-22mm
1x Ratchet Handle	3/8"Dr.
2x 3/8"Dr. Extension Bar	75mm&150mm
1x Universal Joint	3/8"Dr.
1x Sliding Bar	3/8"Dr.

QTY/CTN	CTN SIZE	G.W
6 sets	33.3X31.5x20.3cm	12.8kg



**26**  
PIECES



Name **26-pc 1/2" Dr. Socket Set**

Item No. **FIX MT26**

21x 1/2" Dr. Socket	8-9-10-11-12-13-14-15-16-17-18-19-20-21-22-23-24-25-27-30-32mm
1x Ratchet Handle	1/2"Dr.
2x 1/2"Dr. Extension Bar	125mm&250mm
1x Universal Joint	1/2"Dr.
1x Sliding Bar	1/2"Dr.

QTY/CTN	CTN SIZE	G.W
4 sets	46x25.5x20.5cm	15.5kg





**111**  
PIECES

**Name** 111-pc 1/4" & 1/2"Dr. Socket Tool Set

**Item No. FIX OMCBT111**

18x 1/2"Dr. Socket	10-11-12-13-14-15-16-17-18-19-20-21-22-23-24-27-30-32mm
13x 1/4"Dr. Socket	4-4.5-5-5.5-6-7-8-9-10-11-12-13-14mm
2x Universal Joint	1/2", 1/4" Dr.
1x Sliding Bar	1/4" Dr.
2x Ratchet Handle	1/2", 1/4" Dr.
1x Spinner Handle	1/4" Dr.
4x Extension Bar	1/2" Dr. 125&250mm, 1/4" Dr. 50&100mm
1x Three Way	1/2" Dr
2x 1/2"Dr. Spark Plug Socket	16mm & 21mm
3x 1/2"Dr. Impact Socket	17-19-21mm
11x Combination Wrench	8-9-10-11-12-13-14-15-16-17-19mm
1x Coupler	1/2" x 5/16"
27x 5/16" Dr. Bit	SL:4-5-5.5-6-6.5-7-8mm ,PH:1-2-3-4 ,H:4-5-6-7-8mm, T:20-25-27-30-40-45-50 , PZ:1-2-3-4
3x Hinged Socket Wrench	10x11, 12x13, 14x15mm
3x Hex Key Wrench	1.5-2-2.5mm
9x Hex Key Wrench	1.5-2-2.5-3-4-5-6-8-10mm
9 x Torx Key Wrench	T10-T15-T20-T25-T27-T30-T40-T45-T50
1x Plastic Case	120x62x36mm

QTY/CTN	CTN SIZE	G.W
3 sets	42.7x31.2x31cm	26.5kg





**42**  
PIECES

**Cr-V**

**Cr-V**  
50BV30

**MICRO**  
FINISH

**DIN**  
3124

Name	Cantilever Mechanical Tool Set	
Item No.	FIX MT42	
Metal Box Size:	360x220x220mm	
Contents		
1 x Ratchet Handle:	1/2" Dr.	
2 x Extension Bars:	1/2" Dr.x125mm 1/2"Dr.x250mm	
1 x Universal Joint:	1/2" Dr.	
1 x Sliding Bar:	1/2" Dr.	
1 x Flexible Handle:	1/2" Dr.x10"	
2 x Spark Plug Sockets:	1/2" Dr.x16mm 1/2"Dr.x21mm	
20 x 1/2" Sockets	1/2" Dr.8-9-10-11-12-13-14-15-16-17-18-19-20-21-22-23-24-27-30-32mm	
12 x Combination Wrench:	8-9-10-11-12-13-14-15-17-19-21-22mm	
1 x Combination Pliers:	7"	
1 x Diagonal Cutting Pliers:	6"	
1 x Long Nose Pliers	6"	



## Cantilever Mechanical Tool Box Empty

FIX Z0602





**65**  
PIECES

**Cr-V**

**Cr-V**  
50BV30

**MICRO**  
FINISH

**DIN**  
3124

Name **Cantilever Mechanical Tool Set**

Item No. **FIX MT62**

1 x Combination Pliers	7" 180mm
1 x Diagonal Cutting Pliers	6" 150mm
1 x Long Nose Pliers	6" 150mm
1 x Ratchet Handle	1/2"Dr.
1 x Flexible Handle	1/2 x 12" 300mm
1 x Universal Joint	1/2" Dr.
1 x Spark Plug Socket	1/2" Dr. x 21mm
1 x Sliding Bar	1/2" Dr. x 250mm
9 x Ball ended long allen keys	1.5 - 2 - 2.5 - 3 - 4 - 5 - 6 - 8 - 10
3 x Phillips Screwdrivers	Ph1 x 75mm Ph2 x 100mm Ph3 x 150mm
3 x Slotted Screwdrivers	5.5 x 1.0 x 6.5 x 1.2 x 125mm 8 x 1.2 x 150mm
3 x Extension Bar	1/2"Dr. x 75mm 1/2"Dr. x 125mm 1/2"Dr. x 250mm
18 x Combination Wrenches	6 - 7-8-9-10-11-12-13-14-15-16-17-18-19-20-21-25mm
18 x 1/2" Dr.socket	10-11-12-13-14-15-16-17-18-19-20-21-22-23-24-27-30-32mm

# Sockets and Accessories

Ratchet Handle, Socket, Bit Sockets, Extension Bar, Spark Plug Socket...



Don't strike or use as a hammer!

The ergonomic features of series OMC optimised handles for increased comfort. The unified LOGO section, to achieve a better and longer presentation.

5

CR-MO mechanism and CR-V steel body.

4

This switch gives a three-way working: forward, idle and backward.

3

Quick release button for socket quicker setting on and off.

2

Engineering design

1

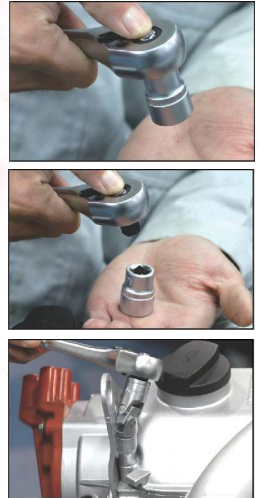

## Ratchets

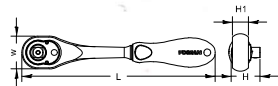

No.	□	L mm	H mm	H1 mm	W mm	A mm	g	
FIX J0101	1/4"Dr.	150	24	12.8	26.8	6.2	145.0	6/96
FIX J0102	3/8"Dr.	220	32.5	16.8	32.5	9.4	330.0	6/48
FIX J0103	1/2"Dr.	260	42	21	40	12.5	625.0	6/36

## 1/4" Dr. Socket

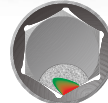
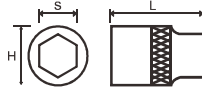

Increased Contact Area



Color Box

METRIC No.	S mm	H mm	L mm	g	☒/☒
FIX H0101M	4mm	11.8	25	15.0	24/240
FIX H0103M	5mm	11.8	25	15.0	24/240
FIX H0105M	6mm	11.8	25	15.0	24/240
FIX H0106M	7mm	11.8	25	15.0	24/240
FIX H0107M	8mm	11.8	25	15.0	24/240
FIX H0108M	9mm	12.8	25	15.0	24/240
FIX H0109M	10mm	14.5	25	20.0	24/240
FIX H0110M	11mm	15.8	25	20.0	24/240
FIX H0111M	12mm	16.8	25	25.0	24/240
FIX H0112M	13mm	17.8	25	25.0	24/240
FIX H0113M	14mm	19.8	25	30.0	24/240

## 1/2" Dr. Socket

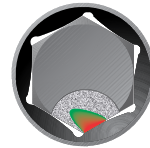

Increased Contact Area

METRIC No.	SAE No.	S mm	S Inch	H mm	L mm	g	☒/☒
FIX H0301M	H0301S	8mm	5/16	21.8	38	50	12/240
FIX H0302M	/	9mm	/	21.8	38	50	12/240
FIX H0303M	H0303S	10mm	3/8	21.8	38	55	12/240
FIX H0304M	H0304S	11mm	7/16	21.8	38	55	12/240
FIX H0305M	/	12mm	/	21.8	38	55	12/240
FIX H0306M	H0306S	13mm	1/2	21.8	38	55	12/240
FIX H0307M	H0307S	14mm	9/16	21.8	38	60	12/240
FIX H0308M	H0308S	15mm	19/32	21.8	38	55	12/240
FIX H0309M	H0309S	16mm	5/8	21.8	38	55	12/240
FIX H0310M	H0310S	17mm	11/16	23.8	38	70	12/240
FIX H0311M	/	18mm	/	24.8	38	80	12/240
FIX H0312M	H0312S	19mm	3/4	25.8	38	65	12/240
FIX H0313M	/	20mm	/	27.8	38	85	12/240
FIX H0314M	H0314S	21mm	13/16	27.8	38	80	12/240
FIX H0315M	H0315S	22mm	7/8	29.8	38	100	12/120
FIX H0316M	/	23mm	/	31.8	40	115	12/120
FIX H0317M	H0317S	24mm	15/16	31.8	40	105	12/120
FIX H0318M	H0318S	25mm	1	33.8	42	125	12/120
FIX H0319M	H0319S	27mm	1-1/16	35.8	42	140	12/120
FIX H0320M	H0320S	30mm	1-3/16	39.8	44	170	12/120
FIX H0321M	H0321S	32mm	1-1/4	41.8	45	175	12/120



## 1/4" Dr. E Socket

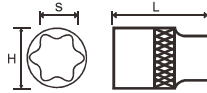

Color Box



No.	S mm	H mm	L mm	g	Box
FIX H0701M	E4	11.8	25	15.0	24/240
FIX H0702M	E5	11.8	25	15.0	24/240
FIX H0703M	E6	11.8	25	15.0	24/240
FIX H0704M	E7	11.8	25	15.0	24/240
FIX H0705M	E8	12.8	25	15.0	24/240

## 3/8" Dr. E Socket

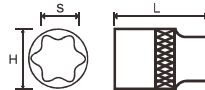

Color Box



No.	S mm	H mm	L mm	g	Box
FIX H0801M	E4	16.8	29.0	25.0	12/240
FIX H0802M	E5	16.8	29.0	25.0	12/240
FIX H0803M	E6	16.8	29.0	25.0	12/240
FIX H0804M	E7	16.8	29.0	25.0	12/240
FIX H0805M	E8	16.8	29.0	25.0	12/240
FIX H0806M	E10	16.8	29.0	25.0	12/240
FIX H0807M	E11	16.8	29.0	25.0	12/240
FIX H0808M	E12	16.8	29.0	25.0	12/240
FIX H0809M	E14	17.8	29.0	25.0	12/240
FIX H0810M	E16	19.8	29.0	35.0	12/240
FIX H0811M	E18	21.8	29.0	50.0	12/240
FIX H0812M	E20	23.8	29.0	65.0	12/120

## 1/2" Dr. E Socket

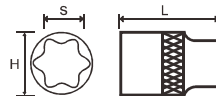

Color Box



No.	S mm	H mm	L mm	g	Box
FIX H0901M	E10	21.8	38	55.0	12/120
FIX H0902M	E11	21.8	38	55.0	12/120
FIX H0903M	E12	21.8	38	55.0	12/120
FIX H0904M	E14	21.8	38	55.0	12/120
FIX H0905M	E16	21.8	38	60.0	12/120
FIX H0906M	E18	21.8	39	75.0	12/120
FIX H0907M	E20	23.8	39	80.0	12/120
FIX H0908M	E22	25.8	9	95.0	12/120
FIX H0909M	E24	27.8	39	100.0	12/240

## 1/4" Dr. E-Deep Socket

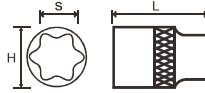

Color Box



No.	S mm	H mm	L mm	g	Box / Tray
FIX H1001M	E4	11.8	50	20	12/240
FIX H1002M	E5	11.8	50	20	12/240
FIX H1003M	E6	11.8	50	20	12/240
FIX H1004M	E7	11.8	50	20	12/240
FIX H1005M	E8	12.8	50	25	12/240

## 1/2" Dr. E-Deep Socket

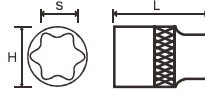

Color Box



No.	S mm	H mm	L mm	g	Box / Tray
FIX H1101M	E14	21.8	77	115	6/120
FIX H1102M	E16	21.8	77	130	6/120
FIX H1103M	E18	21.8	77	150	6/120
FIX H1104M	E20	23.8	77	150	6/120
FIX H1105M	E22	25.8	77	170	6/60
FIX H1106M	E24	27.8	77	195	6/60
FIX H1107M	E10	21.8	77	110	6/120
FIX H1108M	E11	21.8	77	115	6/120
FIX H1109M	E12	21.8	77	120	6/120

## 3/8" Dr. Hexagonal Socket

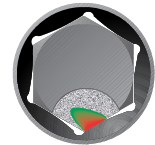
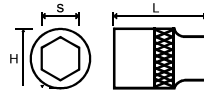

Increased Contact Area

METRIC No.	S mm	S Inch	H mm	L mm	g	Box / Tray
H0201M	8mm	5/16	16.8	28	25.0	12/240
H0202M	9mm	11/32	16.8	28	25.0	12/240
H0203M	10mm	3/8	16.8	28	30.0	12/240
H0204M	11mm	7/16	16.8	28	30.0	12/240
H0205M	12mm	/	17.8	28	30.0	12/240
H0206M	13mm	1/2	18.8	28	30.0	12/240
H0207M	14mm	9/16	19.8	28	35.0	12/240
H0208M	15mm	/	21.8	28	35.0	12/240
H0209M	16mm	5/8	21.8	28	40.0	12/240
H0210M	17mm	11/16	23.8	30	50.0	12/120
H0211M	18mm	/	25.8	30	55.0	12/120
H0212M	19mm	3/4	25.8	30	55.0	12/120
H0213M	20mm	/	27.8	30	60.0	12/120
H0214M	21mm	13/16	27.8	30	60.0	12/120
H0215M	22mm	7/8	29.8	30	75.0	12/120
H0216M	23mm	/	31.8	32	85.0	12/120
H0217M	24mm	15/16	31.8	32	95.0	12/120
H0218M	6mm	7/16	16.8	28	25.0	12/240
H0219M	7mm	7/16	16.8	28	25.0	12/240



## 1/4" Dr. Deep Hexagonal Socket

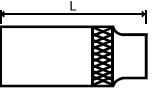

METRIC No.	S mm	S Inch	H mm	L mm	g	Box / Carton
H0401M	4mm	5/32	11.8	50	25.0	12/240
H0402M	5mm	3/16	11.8	50	25.0	12/240
H0403M	6mm	1/4	11.8	50	25.0	12/240
H0404M	7mm	9/32	11.8	50	25.0	12/240
H0405M	8mm	5/16	11.8	50	25.0	12/240
H0406M	9mm	11/32	12.8	50	25.0	12/240
H0407M	10mm	3/8	14.8	50	35.0	12/240
H0408M	11mm	7/16	15.8	50	40.0	12/240
H0409M	12mm	/	16.8	50	45.0	12/240
H0410M	13mm	1/2	17.8	50	45.0	12/240
H0411M	14mm	9/16	19.8	50	55.0	12/240

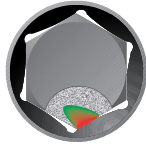

Increased Contact Area



## 3/8" Dr. Hexagonal Deep Socket

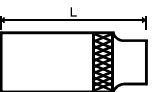

METRIC No.	S mm	S Inch	H mm	L mm	g	Box / Carton
H0501M	8mm	5/16	16.8	63	45.0	6/120
H0502M	9mm	/	16.8	63	50.0	6/120
H0503M	10mm	3/8	16.8	63	50.0	6/120
H0504M	11mm	7/16	16.8	63	55.0	6/120
H0505M	12mm	/	17.8	63	60.0	6/120
H0506M	13mm	1/2	18.8	63	60.0	6/120
H0507M	14mm	9/16	19.8	63	75.0	6/120
H0508M	15mm	19/32	21.8	63	85.0	6/120
H0509M	16mm	5/8	21.8	63	80.0	6/120
H0510M	17mm	11/16	23.8	63	90.0	6/60
H0511M	18mm	/	24.8	63	105.0	6/60
H0512M	19mm	3/4	25.8	63	110.0	6/60
H0513M	21mm	13/16	27.8	63	110.0	6/60
H0514M	22mm	7/8	29.8	63	140.0	6/60
H0515M	23mm	/	31.8	63	165.0	6/60
H0516M	24mm	15/16	31.8	63	185.0	6/60

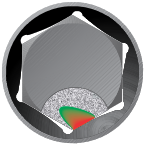

Increased Contact Area



## 1/2" Dr. Hexagonal Deep Socket

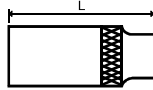

METRIC No.	S mm	S Inch	H mm	L mm	g	Box/Case
H0601M	8mm	5/16	21.8	77	85.0	6/120
H0602M	9mm	/	21.8	77	85.0	6/120
H0603M	10mm	3/8	21.8	77	95.0	6/120
H0604M	11mm	7/16	21.8	77	95.0	6/120
H0605M	12mm	/	21.8	77	105.0	6/120
H0606M	13mm	1/2	21.8	77	110.0	6/120
H0607M	14mm	9/16	21.8	77	110.0	6/120
H0608M	15mm	/	21.8	77	105.0	6/120
H0609M	16mm	5/8	21.8	77	100.0	6/120
H0610M	17mm	11/16	23.8	77	125.0	6/120
H0611M	18mm	/	24.8	77	145.0	6/120
H0612M	19mm	3/4	25.8	77	130.0	6/120
H0613M	21mm	13/16	27.8	77	155.0	6/120
H0614M	22mm	7/8	29.8	77	195.0	6/60
H0615M	24mm	15/16	31.8	77	195.0	6/60
H0616M	27mm	1-1/16	35.8	77	260.0	6/60
H0617M	30mm	1-3/16	39.8	77	280.0	6/60
H0618M	32mm	1-1/4	41.8	77	305.0	6/60
H0619M	20mm	13/16	27.8	77	160.0	6/120

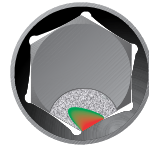

Increased Contact Area



## Extension Bar



No.	S mm	H mm	L mm	g	Box/Case
FIX J0301	1/4" Dr.	12.3	50.0	20.0	24/240
FIX J0302	1/4" Dr.	12.3	75.0	35.0	12/240
FIX J0303	1/4" Dr.	12.3	100.0	45.0	24/240
FIX J0304	3/8" Dr.	12.3	75.0	75.0	24/240
FIX J0305	3/8" Dr.	16.8	150.0	140.0	12/120
FIX J0306	3/8" Dr.	16.8	250.0	240.0	6/60
FIX J0307	1/2" Dr.	16.8	75.0	140.0	24/120
FIX J0308	1/2" Dr.	21.8	125.0	200.0	6/60
FIX J0309	1/2" Dr.	21.8	250.0	395.0	6/60

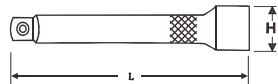

Color Box

## Universal Joint



No.	S mm	H mm	L mm	g	Box/Case
FIX J0401	1/4" Dr.	14.0	38.0	30.0	10/120
FIX J0402	3/8" Dr.	18.0	55.0	75.0	10/120
FIX J0403	1/2" Dr.	24.8	73.0	160.0	10/120

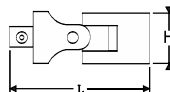

## Spark Plug Socket



No.	S mm	H mm	L mm	g	
FIX J0501	3/8"x16mm	21.8	63.0	90.0	10/100
FIX J0502	3/8"x21mm	27.8	65.0	125.0	10/100
FIX J0503	1/2"x16mm	21.8	63.0	85.0	10/100
FIX J0504	1/2"x21mm	27.8	65.0	135.0	10/100

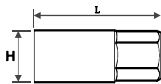

## Bit Coupler



No.	S mm	H mm	L mm	g	
FIX J0601	1/2x5/16	24.7	38	75.0	10/120
FIX J0602	1/2x10	24.7	38	75.0	10/120
FIX J0603	3/8x1/4	24.7	38	75.0	10/120
FIX J0604	3/8x5/16	24.7	38	75.0	10/120
FIX J0605	3/8x10	17.0	38	75.0	10/120
FIX J0606	1/4x1/4	12.0	24	15.0	10/120

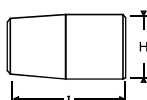

## Adaptor



No.	S mm	H mm	L mm	g	
FIX J0701	1/4Fx3/8M	12	25	20.0	10/120
FIX J0702	3/8Fx1/4M	17	27	15.0	10/120
FIX J0703	3/8Fx1/2M	17	35	50.0	10/120
FIX J0704	1/2Fx3/8M	22	34	45.0	10/120

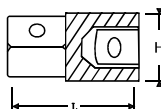

## 1/4" Dr. Hexagon Bit Socket



No.	Ø	H mm	L mm	g	
FIX J0801	H3	12	37.5	20.0	20/240
FIX J0802	H4	12	37.5	20.0	20/240
FIX J0803	H5	12	37.5	20.0	20/240
FIX J0804	H6	12	37.5	20.0	20/240
FIX J0805	H8	12	37.5	20.0	20/240

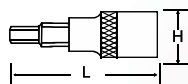

## 1/4" Dr. Torx Bit Socket



No.	Icon	H mm	L mm	Weight g	Box/Case
FIX J0806	T8	12	37.5	20.0	20/240
FIX J0807	T10	12	37.5	20.0	20/240
FIX J0808	T15	12	37.5	20.0	20/240
FIX J0809	T20	12	37.5	20.0	20/240
FIX J0810	T25	12	37.5	20.0	20/240
FIX J0811	T30	12	37.5	20.0	20/240
FIX J0812	T40	12	37.5	20.0	20/240

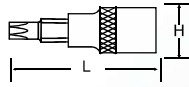

## 1/4" Dr. Slotted Bit Socket



No.	Icon	H mm	L mm	Weight g	Box/Case
FIX J0813	SL4	12	37.5	20.0	20/240
FIX J0814	SL5.5	12	37.5	20.0	20/240
FIX J0815	SL7	12	37.5	20.0	20/240

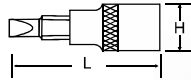

## 1/4" Dr. Phillips Bit Socket



No.	Icon	H mm	L mm	Weight g	Box/Case
FIX J0816	PH0	12	37.5	20.0	20/240
FIX J0817	PH1	12	37.5	20.0	20/240
FIX J0818	PH2	12	37.5	20.0	20/240
FIX J0819	PH3	12	37.5	20.0	20/240

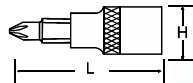

## 1/4" Dr. Pozidriv Bit Socket



No.	Icon	H mm	L mm	Weight g	Box/Case
FIX J0820	PZ0	12	37.5	20.0	20/240
FIX J0821	PZ1	12	37.5	20.0	20/240
FIX J0822	PZ2	12	37.5	20.0	20/240
FIX J0823	PZ3	12	37.5	20.0	20/240

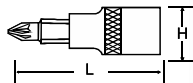

## 3/8" Dr. Hexagon Bit Socket



No.	⊕	H mm	L mm	i g	📦
FIX J0901	H3	16.8	50.0	40.0	20/240
FIX J0902	H4	16.8	50.0	40.0	20/240
FIX J0903	H5	16.8	50.0	40.0	20/240
FIX J0904	H6	16.8	50.0	40.0	20/240
FIX J0905	H7	16.8	50.0	40.0	20/240
FIX J0906	H8	16.8	50.0	40.0	20/240
FIX J0907	H9	16.8	50.0	40.0	20/240
FIX J0908	H10	16.8	50.0	40.0	20/240
FIX J0909	H12	16.8	50.0	40.0	20/240
FIX J0910	H14	16.8	50.0	40.0	20/240
FIX J0939	H5.5	16.8	50.0	40.0	20/240

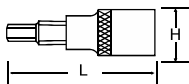

## 3/8" Dr. Torx Bit Socket



No.	⊕	H mm	L mm	i g	📦
FIX J0911	T8	16.8	50.0	40.0	20/240
FIX J0912	T10	16.8	50.0	40.0	20/240
FIX J0913	T15	16.8	50.0	40.0	20/240
FIX J0914	T20	16.8	50.0	40.0	20/240
FIX J0915	T25	16.8	50.0	40.0	20/240
FIX J0916	T27	16.8	50.0	40.0	20/240
FIX J0917	T30	16.8	50.0	40.0	20/240
FIX J0918	T40	16.8	50.0	40.0	20/240
FIX J0919	T45	16.8	50.0	40.0	20/240
FIX J0920	T47	16.8	50.0	40.0	20/240
FIX J0921	T50	16.8	50.0	40.0	20/240
FIX J0922	T55	16.8	50.0	50.0	20/240
FIX J0923	T60	16.8	50.0	50.0	20/240

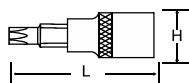

## 3/8" Dr. Slotted Bit Socket



No.	⊖	H mm	L mm	i g	📦
FIX J0924	SL3	12.0	50.0	40.0	20/240
FIX J0925	SL3.5	12.0	50.0	40.0	20/240
FIX J0926	SL4	12.0	50.0	40.0	20/240
FIX J0927	SL5.5	12.0	50.0	40.0	20/240
FIX J0928	SL6.5	12.0	50.0	40.0	20/240
FIX J0929	SL7	12.0	50.0	40.0	20/240
FIX J0930	SL8	12.0	50.0	40.0	20/240

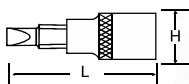

## 3/8" Dr. Phillips Bit Socket



No.	+	H mm	L mm	g	Box/Bag
FIX J0931	PH1	16.8	50.0	40.0	20/240
FIX J0932	PH2	16.8	50.0	40.0	20/240
FIX J0933	PH3	16.8	50.0	40.0	20/240
FIX J0934	PH4	16.8	50.0	40.0	20/240

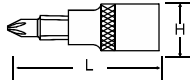

## 3/8" Dr. Pozidriv Bit Socket



No.	+	H mm	L mm	g	Box/Bag
FIX J0935	PZ1	16.8	50.0	40.0	20/240
FIX J0936	PZ2	16.8	50.0	40.0	20/240
FIX J0937	PZ3	16.8	50.0	40.0	20/240
FIX J0938	PZ4	16.8	50.0	40.0	20/240

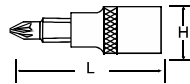

## 3/8" Dr. Torx Bit Socket



No.	+	H mm	L mm	g	Box/Bag
FIX J0941	T8H	16.8	50.0	40.0	20/240
FIX J0942	T0H	16.8	50.0	40.0	20/240
FIX J0943	T15H	16.8	50.0	40.0	20/240
FIX J0944	T20H	16.8	50.0	40.0	20/240
FIX J0945	T25H	16.8	50.0	40.0	20/240
FIX J0946	T27H	16.8	50.0	40.0	20/240
FIX J0947	T30H	16.8	50.0	40.0	20/240
FIX J0948	T40H	16.8	50.0	40.0	20/240
FIX J0949	T45H	16.8	50.0	40.0	20/240
FIX J0950	T50H	16.8	50.0	40.0	20/240
FIX J0951	T60H	16.8	50.0	40.0	20/240
FIX J0952	T55H	16.8	50.0	40.0	20/240

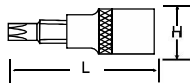

## 3/8" Dr. Slotted Bit Socket



No.	+	H mm	L mm	g	Box/Bag
FIX J0953	M5	16.8	50.0	40.0	20/240
FIX J0954	M6	16.8	50.0	40.0	20/240
FIX J0955	M8	16.8	50.0	40.0	20/240
FIX J0956	M9	16.8	50.0	40.0	20/240
FIX J0957	M10	16.8	50.0	40.0	20/240
FIX J0958	M12	16.8	50.0	40.0	20/240

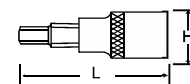

## 1/2" Dr. Hexagon Bit Socket



No.	Ø	H mm	L mm	g	Box/Pack
FIX J1001	H6	22	100	80.0	10/120
FIX J1002	H7	22	100	80.0	10/120
FIX J1003	H8	22	100	130.0	10/120
FIX J1004	H10	22	100	130.0	10/120
FIX J1005	H12	22	100	155.0	10/120
FIX J1006	H14	22	100	155.0	10/120

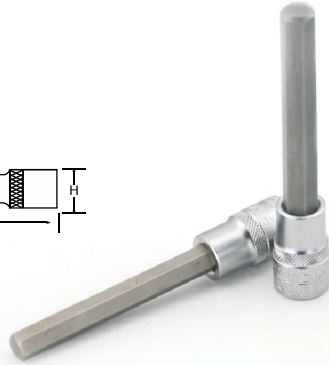
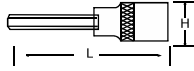

## Sliding Bar



No.	S mm	L mm	g	Box/Pack
FIX J1101	1/2"	250	355	5/40



## Flexible Handle



No.	S mm	L mm	g	Box/Pack
FIX J1203	1/2"x12"	300	740	5/40
FIX J1202	3/8"x10"	255	290	10/120



## 12-pc Socket Set



### Item No. FIX P4012M

1/2" Dr. Socket 10-11-12-13-14-15-17-19-21-24mm

1/2" Dr. Extension Bar 125mm

Ratchet Handle 1/2" Dr.

QTY/CTN	CTN SIZE	G. W
10sets	35x27x22cm	15.5kg



# Wrenches

Adjustable Wrenches, Combination Wrenches, Ring Wrenches, Open End Wrenches...





## Adjustable Wrench

**Cr-V** **NON-SLIP**



No.	Size	H mm	H1 mm	L mm	W mm	W1 mm	A mm	B mm	g		
FIX B0101	6"	13.5	9.8	158	29	45	19.5	18.5	140.0	6	120
FIX B0102	8"	17	11.3	208	35	56	24.5	24	270.0	6	72
FIX B0103	10"	20.5	14	258	42	66	30.5	28.5	440.0	6	54

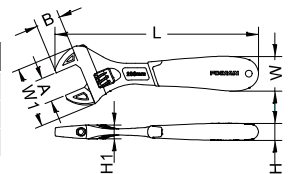

## Combination Wrench

**Cr-V** **DIN 3113** **MICRO FINISH**

12-point profile for a high torque without damaging.

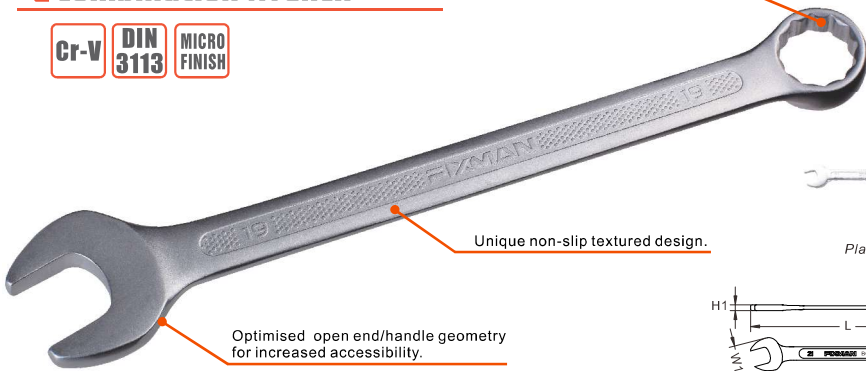

Unique non-slip textured design.

Optimised open end/handle geometry for increased accessibility.

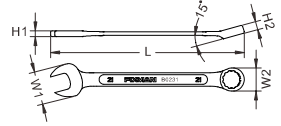

No.	Size	H1 mm	H2 mm	L mm	W1 mm	W2 mm	g	Box/Pkg
FIX B0201	6mm	4.5	5.5	110	14.5	11	22.0	6/120
FIX B0202	7mm	4.5	5.5	120	16	12	24.0	6/120
FIX B0203	8mm	5	6	130	18.5	13.5	26.0	6/120
FIX B0204	9mm	5.5	6.5	140	20.5	15	34.0	6/120
FIX B0205	10mm	5.5	6.5	150	22.5	16	43.0	6/120
FIX B0206	11mm	6	7	160	24	18	49.0	6/120
FIX B0207	12mm	6	8	170	26.5	19	63.0	6/120
FIX B0208	13mm	6	8.5	180	28	20.5	72.0	6/120
FIX B0209	14mm	6	8.5	190	30.5	22	88.0	6/120
FIX B0210	15mm	7	9	200	32	23.5	101.0	6/120
FIX B0211	16mm	7	10	210	35	25	108.0	6/120
FIX B0212	17mm	7.5	10	220	37	26	128.0	6/120
FIX B0213	18mm	7.5	10.5	230	39	27.5	145.0	6/120
FIX B0214	19mm	8	11	240	41	28.5	167.0	6/60
FIX B0215	20mm	8	11	250	42	29	190.0	6/60
FIX B0216	21mm	8	11.5	260	44	31	224.0	6/60
FIX B0217	22mm	8.5	11.5	270	46	32.5	226.0	6/60
FIX B0218	23mm	8.5	12	280	48	34.5	261.0	6/60
FIX B0219	24mm	9	12.5	290	50.5	35	281.0	6/60
FIX B0220	26mm	9.5	13	310	54	38	313.0	6/48
FIX B0221	27mm	9.5	13	320	56.5	39	363.0	6/48
FIX B0222	28mm	10	14.5	330	58.5	40.5	430.0	6/48
FIX B0223	29mm	10	14.5	340	60	42	470.0	6/48
FIX B0224	30mm	10	15.5	350	62	44	512.0	6/48
FIX B0225	32mm	11	16	370	66	46	522.0	6/36



## Flexible Ratchet Combination Wrench

**Cr-V** **MICRO FINISH**

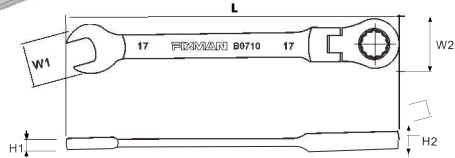

Plastic Hanger

No.	Size	H1 mm	H2 mm	L mm	W1 mm	W2 mm	g	Box/Pack
FIX B0701	8mm	4.7	7.7	138	21.2	20.2	73	6/96
FIX B0702	9mm	4.7	7.7	138	21.2	20.2	73	6/96
FIX B0703	10mm	5.3	8.2	156	25.1	22.1	96	6/96
FIX B0704	11mm	5.9	8.5	174	27.1	24.1	116	6/96
FIX B0705	12mm	6.5	9.4	192	31	27.6	153	6/96
FIX B0706	13mm	6.5	9.4	192	31	27.6	153	6/96
FIX B0707	14mm	7.1	9.7	210	32	30.5	200	6/96
FIX B0708	15mm	7.1	9.7	210	32	30.5	200	6/96
FIX B0709	16mm	7.7	10.8	229	37.9	33.5	250	6/72
FIX B0710	17mm	7.7	10.8	229	37.9	33.5	250	6/72
FIX B0711	18mm	8.3	11.3	247	40.9	36.5	300	6/72
FIX B0712	19mm	8.3	11.3	247	40.9	36.5	300	6/72
FIX B0714	21mm	8.3	11.8	258	44.6	40.4	380	6/72
FIX B0715	22mm	8.85	11.8	258	44.6	40.4	380	6/48
FIX B0717	24mm	9.4	12.3	268	52.5	45.1	440	6/48
FIX B0718	25mm	9.4	12.3	268	52.5	45.1	440	6/48
FIX B0719	27mm	10.2	13.1	290	56.5	49.1	550	6/48
FIX B0720	30mm	11.2	14.1	317	56.5	54.8	670	6/36
FIX B0721	32mm	12.4	15.8	383	69.4	60	1050	6/36

## Hinged Socket Wrench

**Cr-V** **MICRO FINISH**

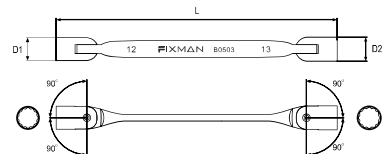

No.	Size	D1 mm	D2 mm	L mm	g	Box/Pack
FIX B0501	8x9mm	14	14	205	84	6/48
FIX B0502	10x11mm	17	17	220	120	6/48
FIX B0503	12x13mm	20	20	230	170	6/48
FIX B0504	14x15mm	23	23	250	205	6/48
FIX B0505	16x17mm	25	25	260	300	6/48
FIX B0506	18x19mm	26	26	282	350	6/48

## Reversible Gear Wrench

**Cr-V** **MICRO FINISH** **72T**

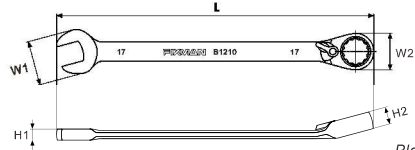

Plastic Hanger

No.	Size	H1 mm	H2 mm	L mm	W1 mm	W2 mm	g	
FIX B1201	8mm	4.7	7.7	130	21.2	20.2	61	6/96
FIX B1202	9mm	4.7	7.7	130	21.2	20.2	61	6/96
FIX B1203	10mm	5.3	8.2	147	25.1	22.1	80	6/96
FIX B1204	11mm	5.9	8.5	165	27.1	24.1	105	6/96
FIX B1205	12mm	6.5	9.4	183	31	27.6	140	6/96
FIX B1206	13mm	6.5	9.7	183	31	27.6	140	6/96
FIX B1207	14mm	7.1	9.7	200	32	30.5	160	6/96
FIX B1208	15mm	7.1	9.7	200	32	30.5	160	6/96
FIX B1209	16mm	7.7	10.8	218	37.9	33.5	220	6/72
FIX B1210	17mm	7.7	10.8	218	37.9	33.5	220	6/72
FIX B1211	18mm	8.3	11.3	236	4.9	36.5	275	6/72
FIX B1212	19mm	8.3	11.3	236	40.9	36.5	275	6/72
FIX B1213	20mm	8.3	11.8	246	44.6	40.4	330	6/72
FIX B1214	21mm	8.85	11.8	246	44.6	40.4	330	6/48
FIX B1215	22mm	9.4	12.3	267	52.5	45.1	420	6/48
FIX B1218	25mm	9.4	12.3	267	52.5	45.1	420	6/36
FIX B1220	27mm	10.2	13.1	290	56.6	49.1	525	6/36
FIX B1223	30mm	11.2	14.1	318	56.6	54.8	525	6/36
FIX B1224	32mm	12.4	15.8	385	69.4	60	950	6/36

# Wrench



## Combanion Ratcheting Wrench

**Cr-V** **MICRO FINISH**

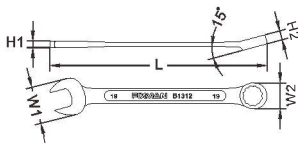

Plastic Hanger

No.	Size	H1 mm	H2 mm	L mm	W1 mm	W2 mm	g	Box/Pack
FIX B1301	8mm	4.7	7.7	132	21.2	20.2	61	6/96
FIX B1302	9mm	4.7	7.7	132	21.2	20.2	61	6/96
FIX B1303	10mm	5.3	8.2	149	25.1	22.1	80	6/96
FIX B1304	11mm	5.9	8.5	167	27.1	24.1	105	6/96
FIX B1305	12mm	6.5	9.4	185	31	27.6	140	6/96
FIX B1306	13mm	6.5	9.4	185	31	27.6	140	6/96
FIX B1307	14mm	7.1	9.7	202	32	30.5	160	6/96
FIX B1308	15mm	7.1	9.7	202	32	30.5	160	6/96
FIX B1309	16mm	7.7	10.8	220	37.9	33.5	220	6/72
FIX B1310	17mm	7.7	10.8	220	37.9	33.8	220	6/72
FIX B1311	18mm	8.3	11.3	238	40.9	36.35	275	6/72
FIX B1312	19mm	8.3	11.3	238	40.9	36.5	275	6/72
FIX B1313	21mm	8.3	11.8	247	44.6	40.4	330	6/48
FIX B1314	22mm	8.85	11.8	247	44.6	40.4	330	6/48
FIX B1317	24mm	9.4	12.3	270	52.5	45.1	420	6/36
FIX B1318	25mm	9.4	12.3	270	52.5	45.1	420	6/36
FIX B1320	27mm	10.2	13.1	293	56.6	49.1	525	6/36
FIX B1323	30mm	11.2	14.1	322	56.6	54.8	525	6/36
FIX B1324	32mm	12.4	15.8	388	69.4	60	950	6/36

## T-type Socket Wrench

**Cr-V**

No.	Size	W mm	L mm	g	Box/Pack
FIX B1007	6mm	200	305	265	6/48
FIX B1001	8mm	200	305	280	6/48
FIX B1002	10mm	200	305	285	6/48
FIX B1003	12mm	200	305	300	6/48
FIX B1006	13mm	200	305	330	6/48
FIX B1004	17mm	200	305	350	6/48
FIX B1005	19mm	200	305	365	6/48



Color Card

## Wrench Set



**Cr-V**

**DIN 3113**

**MICRO FINISH**



**Cr-V**

**DIN 3113**

**MICRO FINISH**



**Cr-V**

**DIN 3113**



**MICRO FINISH**



**Cr-V**

**DIN 3113**

**MICRO FINISH**

No.			 
FIX B0907	9 - PC Combination Wrench	8, 10, 11, 12, 13, 14, 15, 17, 19mm	1/24
FIX B0908	11 - PC Combination Wrench	8, 9, 10, 11, 12, 13, 14, 15, 17, 19, 22mm	1/24
FIX B0909	14 - PC Combination Wrench	8, 9, 10, 11, 12, 13, 14, 15, 16, 17, 18, 19, 22, 24mm	1/24
FIX B0910	23 - PC Combination Wrench	6, 7, 8, 9, 10, 11, 12, 13, 14, 15, 16, 17, 18, 19, 20, 21, 22, 23, 24, 25, 27, 30, 32mm	1/24





# Pliers

Combination Pliers, Long Nose Pliers, Diagonal Cutting Pliers.....



## Industrial Pliers



The ergonomic features of series FIXMAN optimised handles for increased comfort. TPE two tone handle, soft and heavy duty.

Industrial quality level, 60CR-V material, forged and fine ground, German style with black finished, Jaw  $\leq 0.2\text{mm}$ , Jawgap  $\leq 0.25\text{mm}$ .

Suitable for gripping and cutting work in precision mechanics, pointed, serrated gripping surfaces.

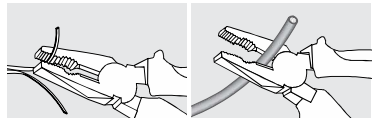

## Industrial Combination Pliers

Cr-V

NON-SLIP

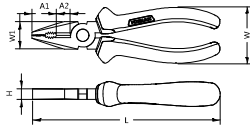

No.	Size	L mm	H mm	W mm	W1 mm	A1 mm	A2 mm	g	Box/Pack
FIXA0507	6"	162	10	54	23	22	12	200.0	6/72
FIXA0505	7"	187	10.5	57	27	22.5	15	310.0	6/72
FIXA0506	8"	200	11.5	60	30	25	16	380.0	6/72

## Industrial Diagonal Cutting Pliers

Cr-V

NON-SLIP

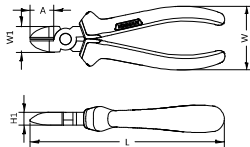

No.	Size	L mm	H1 mm	W mm	W1 mm	A1 mm	g	Box/Pack
FIXA0404	6"	160	10.5	60	22.5	22.5	170.0	6/72
FIXA0405	8"	200	11.5	56	25	27	280.0	6/72

## Industrial Long Nose Pliers

Cr-V

NON-SLIP

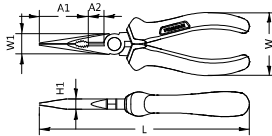

No.	Size	L mm	H1 mm	W mm	W1 mm	A1 mm	A2 mm	g	Box/Pack
FIXA0304	6"	165	8.5	56	16.5	40	12	170.0	6/72
FIXA0305	8"	200	9.5	70	18.5	50	11.5	280.0	6/72

## Industrial Bent Nose Pliers

Cr-V

NON-SLIP

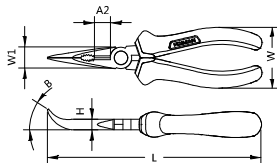

No.	Size	L mm	H mm	W mm	W1 mm	A2 mm	g	Box/Pack
FIXA0204	6"	165	8.5	56	16.5	11.5	170.0	6/72
FIXA0205	8"	200	9	56	18.5	12	280.0	6/72



**General Pliers**

**Groove Joint Pliers**

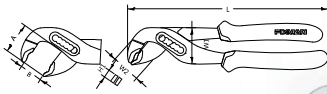

**Cr-V** **NON-SLIP**



No.	Size	L mm	H1 mm	W1 mm	W2 mm	A mm	B mm	g		
<b>FIXA1202</b>	10"	250	8.5	42.5	38	35	35	445.0		



**Mini Pliers**

## Circlip Pliers

### Straight-tip Internal Circlip Pliers

Cr-V

0°

NON-SLIP

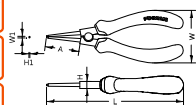

No.	Size	L mm	H mm	H1 mm	W mm	W1 mm	A mm	g	Box/Case
FIXA0601	6"	155	9	1.5	57	5.5	36.5	165.0	6/72
FIXA0602	7"	175	10	1.75	62.5	5.5	43.5	215.0	6/72

### Tip Internal Circlip Pliers

Cr-V

45°

NON-SLIP

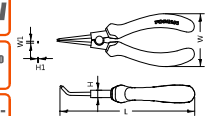

No.	Size	L mm	H mm	H1 mm	W mm	W1 mm	g	Box/Case
FIXA0701	6"	145	9.5	1.5	57	4.5	165.0	6/72
FIXA0702	7"	175	9.5	2	62.5	4.5	210.0	6/72

### Tip Internal Circlip Pliers

Cr-V

90°

NON-SLIP

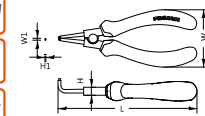

No.	Size	L mm	H mm	H1 mm	W mm	W1 mm	g	Box/Case
FIXA0801	6"	145	9.5	1.5	57	4.5	165.0	6/72
FIXA0802	7"	175	10	2	62.5	4.5	205.0	6/72

### Straight-tip External Circlip Pliers

Cr-V

0°

NON-SLIP

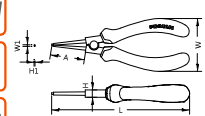

No.	Size	L mm	H mm	H1 mm	W mm	W1 mm	A mm	g	Box/Case
FIXA0901	6"	145	9	1.5	57	3.5	35	165.0	6/72
FIXA0902	7"	185	10	2	65	4.5	45	215.0	6/72





## Tip External Circlip Pliers

**Cr-V**

**45°**

**NON-SLIP**

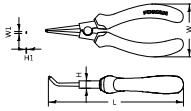

No.	Size	L mm	H mm	H1 mm	W mm	W1 mm	g	Box / Carton
FIXA1001	6"	145	8.5	1.5	52.5	3.5	180.0	6/72
							210.0	6/72

## Tip External Circlip Pliers

**Cr-V**

**90°**

**NON-SLIP**

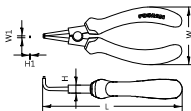

No.	Size	L mm	H mm	H1 mm	W mm	W1 mm	g	Box / Carton
FIXA1101	6"	145	8.5	1.5	52.5	3.5	180.0	6/72
FIXA1102	7"	75	9	2	65	4.5	205.0	6/72

## Lock-Grip Pliers

### Curved Jaw Lock-Grip Pliers

**Cr-V**

**NON-SLIP**

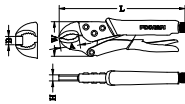

No.	Size	L mm	H mm	W mm	B mm	E mm	g	Box / Carton
FIXA1403	180	10	50.5	25	180.0	6/72		
FIXA1404	225	12.5	65	31.5	560.0	6/36		



### Long Nose Lock-Grip Pliers

**Cr-V**

**NON-SLIP**

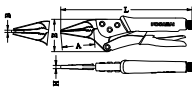

No.	Size	L mm	H mm	A mm	B mm	E mm	g	Box / Carton
FIXA1401	6"	165	5	46.5	16.5	39	180.0	6/72
FIXA1402	9"	225	5	65	19.5	52.5	560.0	6/36



## Lock-Grip Pliers

### C-Type Welding Lock-Grip Pliers

NON-SLIP

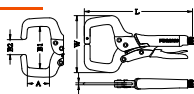

No.	Size	L mm	H mm	W mm	A mm	B1 mm	B2 mm	g	Box	Case
FIXA1408	11"	275	23	137	65	58	119	560	6/24	



### C-Type Welding Lock-Grip Pliers w/Adjustable Tip

NON-SLIP

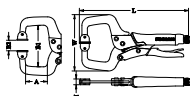

No.	Size	L mm	H mm	W mm	A mm	B1 mm	B2 mm	g	Box	Case
FIXA1409	11"	275	23	137	65	58	119	560	6/24	



### Welding Lock-Grip Pliers

NON-SLIP

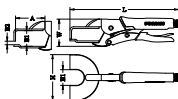

No.	Size	L mm	H mm	H1 mm	W mm	A mm	B1 mm	B2 mm	g	Box	Case
FIXA1405	10"	220	67	22	70	31	11.5	580	4/24		



### Flat Lock-Grip Pliers

NON-SLIP

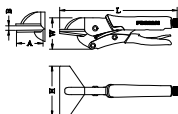

No.	Size	L mm	H mm	W mm	A mm	B mm	g	Box	Case
FIXA1406	10"	245	98	70	45	20	580	3/24	



### Chain Lock-Grip Pliers

NON-SLIP

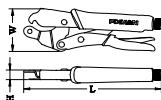

No.	Size	L mm	H mm	W mm	g	Box	Case
FIXA1407	18"	220	19	61.5	560.0	6/24	





# Hammers

Machinist Hammer, Ball Pein Hammer, Mallet...

## Hammer

High carbon steel, forged and hardened. Fine finished by polishing. Jacketed design provides oversize protection for long life and increased safety

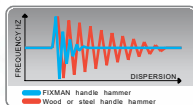

**x3buffer**

Fibreglass handle absorbs shock and vibration. TPE two tone grip, soft and heavy duty. The ergonomic features of series fixman optimised handles reduces the effects of torque on wrists and elbows.

### Machinist Hammer

NON-SLIP

FIBRE GRIP

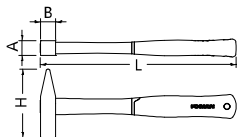

No.	Size	L mm	H mm	A mm	B mm	g	Box/Pack
FIX C0201	300g	300	105	23	23	490.0	4/36
FIX C0202	500g	330	115	27.5	27.5	695.0	4/32

### Ball Pein Hammer

NON-SLIP

FIBRE GRIP

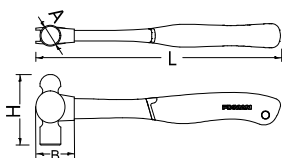

No.	Size	L mm	H mm	A mm	B mm	g	Box/Pack
FIX C0301	12OZ	320	91	30	42	610.0	4/32
FIX C0302	16OZ	325	100	32	45	750.0	4/24

### Mallet

NON-SLIP

FIBRE GRIP

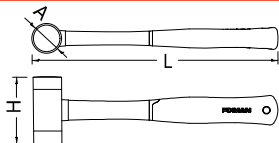

No.	Size	L mm	H mm	A mm	g	Box/Pack
FIX C0502	35mm	300	100	35	475.0	4/24

### Dead Blow Mallet

NON-SLIP

FIBRE GRIP

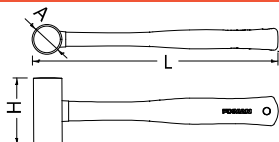

No.	L mm	H mm	A mm	g	Box/Pack
FIX C0701	300	100	40	450.0	4/32

# Cutting Tools

## Hacksaw

### Hacksaw

#### Composite Hacksaw

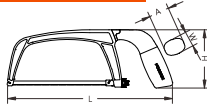

- Easy open lever for quick and easy blade change.
- High tension blade for straight accurate cuts.



No.	Size	L mm	H mm	W mm	A mm	g	Box
FIX K0101	6"	250	87.5	26	32	185.0	6/72



#### Hacksaw

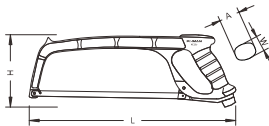

- Easy open lever for quick and easy blade change.
- High tension blade for straight accurate cuts.



No.	Size	L mm	H mm	W mm	A mm	g	Box
FIX K0205	300mm	415	135	27	41	465	6/24



#### Hacksaw

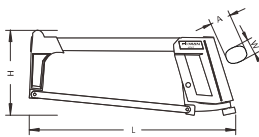

- Easy open lever for quick and easy blade change.
- High tension blade for straight accurate cuts.



No.	Size	L mm	H mm	W mm	A mm	g	Box
FIX K0206	300mm	385	150	24	34	465	6/24





*Update your power!*

FIXMAN

 [www.fixmantools.co.za](http://www.fixmantools.co.za)

Vermont Sales

 011 314 7711

 [orders@vermontsales.co.za](mailto:orders@vermontsales.co.za)

192 Tsesebe Crescent, Corporate park South  
Old Pretoria Road, Randjespark, Midrand, South Africa

 086 688 6633

 [www.vermontsales.co.za](http://www.vermontsales.co.za)